

## **FOR OFF ROAD/RACE USE ONLY**

### **Driven TT Rearsets for 17 - 18 Kawasaki Z 900 Part# DRP -734**

#### **INSTALLATION INSTRUCTIONS**

##### **Removal of Shift (Left) Side**

1. Remove shift rod from bike.
2. Remove frame plate including stock shift lever from bike.

##### **Removal of Brake (Right) Side**

1. Remove heel guard.
2. Remove 2 M8 bolts holding master cylinder.
3. Remove frame bracket.
4. Remove master cylinder plunger pin from brake pedal.
5. Remove rear brake switch and disconnect it from bike.

---

##### **Tools Required**

- 8mm Open End Wrench
  - 5mm Hex Key
  - 6mm Hex Key
  - 8mm Hex Key
  - Needle Nose Pliers
  - Screw Driver
  - Blue Loctite
  - Impact Gun
- 

## **THE USE OF BLUE LOCTITE IS REQUIRED ON ALL MOUNTING HARDWARE**

##### **Installation for Left side**

1. Install foot peg in frame bracket
2. Connect driven shift rod to shift knuckle
3. Install frame bracket onto bike.
4. Adjust shift lever to desired position.

**(For gp shift simple rotate shift knuckle 180 deg)**

##### **Installation for Right side**

1. Install foot peg in frame bracket.
2. Connect master cylinder plunger to brake lever using OEM pin and split pin.
3. Install frame bracket to bike.
4. Install master cylinder using 2 M8 bolts supplied.

**Use blue Loctite on all bolts and torque all to required specs.**

**Install OEM brake switch and spring and make sure brake light activates.**

**Make sure nothing interfere with proper operation of motorcycle.**

**Recheck all bolts after 500 miles of riding.**

**FOR OFF ROAD/RACE USE ONLY**



Standard Shift



GP Shift



Brake Side



**FOR OFF ROAD/RACE USE ONLY**

**Brake Side Assembly**

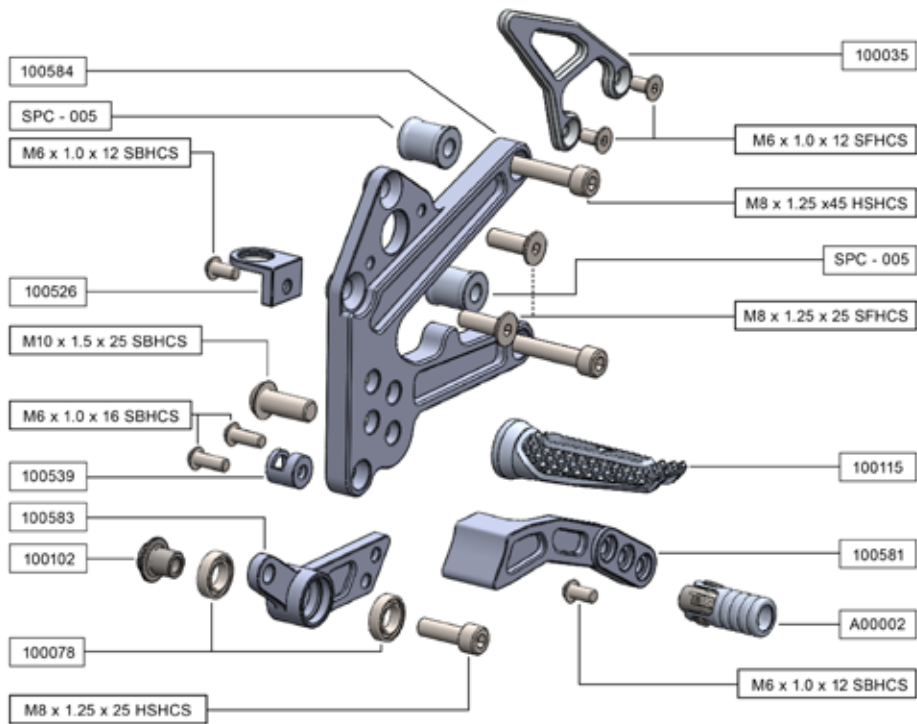

**Shift Side Assembly**

