

**FOR OFF ROAD/RACE USE ONLY!**



*Driven TT Rearsets for 2017 BMW G 310 R*

*Part#:DRP-733*

**INSTALLATION INSTRUCTIONS**

**Removal - Position bike on flat surface**

**Shifter Side**

1. Remove 3 M8 bolts from left side (shifter side) foot peg plate
2. Remove shift rod link hiem joint using small cotter pin (see fig 1 )
3. Reverse left thread with right thread (see fig1)

**Brake Side**

1. Remove m8 exhaust hanger bolt.
2. Remove 3 M8 from right foot peg plate
3. Remove master cylinder cotter pin and pin.
4. Remove master cylinder
5. Remove rear brake switch

**TOOLS REQUIRED**

- 8mm Open End Wrench
- 5mm Hex Key
- 6mm Hex Key
- 8mm Hex Key
- Neele Nose Pliers
- Screw Driver
- Blue Loctite
- Impact Gun

**THE USE OF BLUE LOCTITE IS REQUIRED ON ALL MOUNTING HARDWARE!**

**Installation**

**NOTE: ALL PIVOT POINTS MUST BE TIGHTENED USING BLUE LOCTITE AND AN IMPACT GUN.**

**Shifter Side**

1. Install master cylinder using supplied M6 bolts and nuts.
2. Connect brake switch and spring, bend spring as necessary.
3. Connect rear master cylinder pin and cotter pin to brake pedal.
4. Connect foot peg to driven plate at the desired position
5. Connect plate to bike using supplied m8 bolts.

**PLEASE USE BLUE LOCKTITIE ON ALL BOLTS AND CHECK BRAKE SWITCH OPERATION.**

6. Connect exhaust bracket to bike and reuse rubber damper spacer and bolt.

**Brake Side**

1. Connect foot peg to driven plate at the desired position
2. Connect shift rod to shift knuckle
3. Connect rear set plate to bike using supplied M8 bolts (don't use original bolts)
4. Adjust shifter to desired position.

**PLEASE USE BLUE LOCKTITIE ON ALL BOLTS**

For standard shift (see fig 2)

For reverse shift the front sprocket cover will have to be removed or you can install driven racing sprocket cover part number BMC-001 XX (SEE FIG3)

**TORQUE VALUES**

- M5 = 6FT/LBS
- M6 = 10FT/LBS
- M8 = 25FT/LBS
- M10= 45FT/LBS

**Make final adjustment as necessary and re-check all hardware after the first 500 miles of use.**

**THIS PRODUCT IS INTENDED TO BE INSTALLED BY A CERTIFIED TECHNICIAN\***

**FOR OFF ROAD/RACE USE ONLY!**



**Fig. 1**

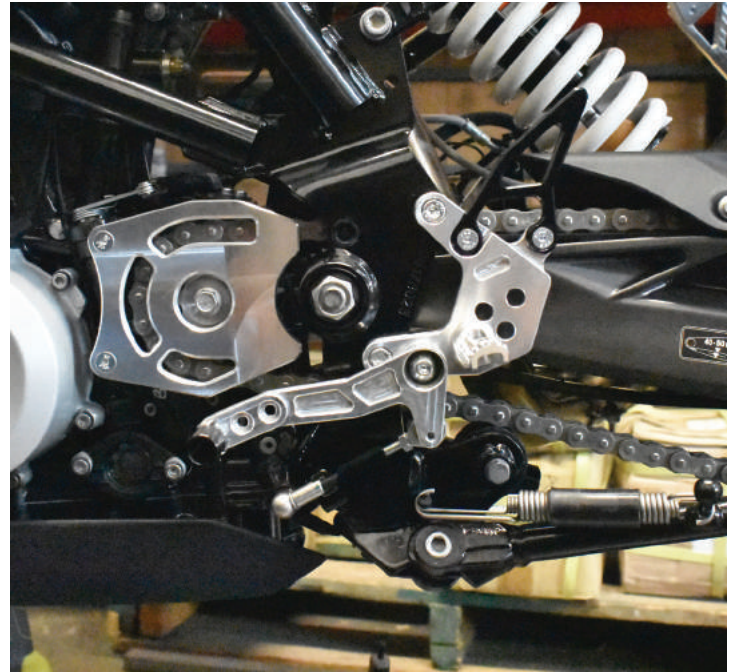

**Fig. 2**

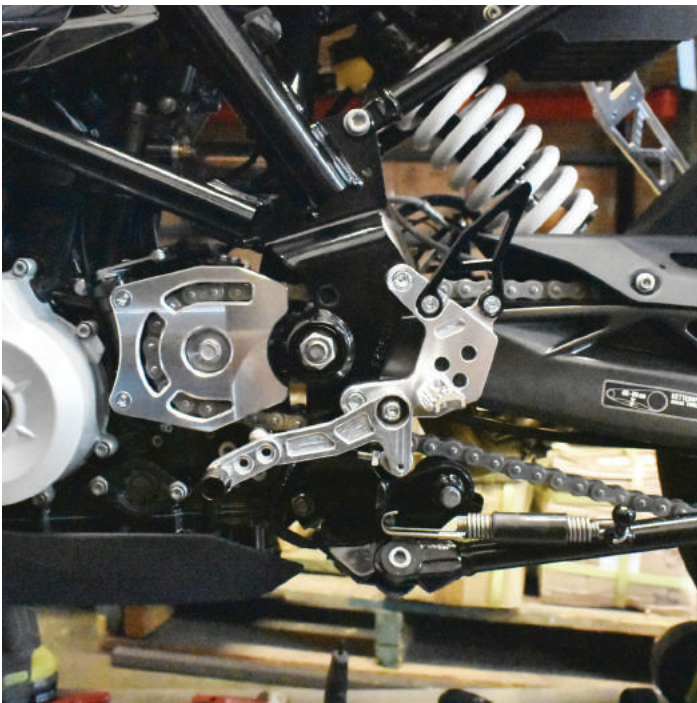

**Fig. 3**

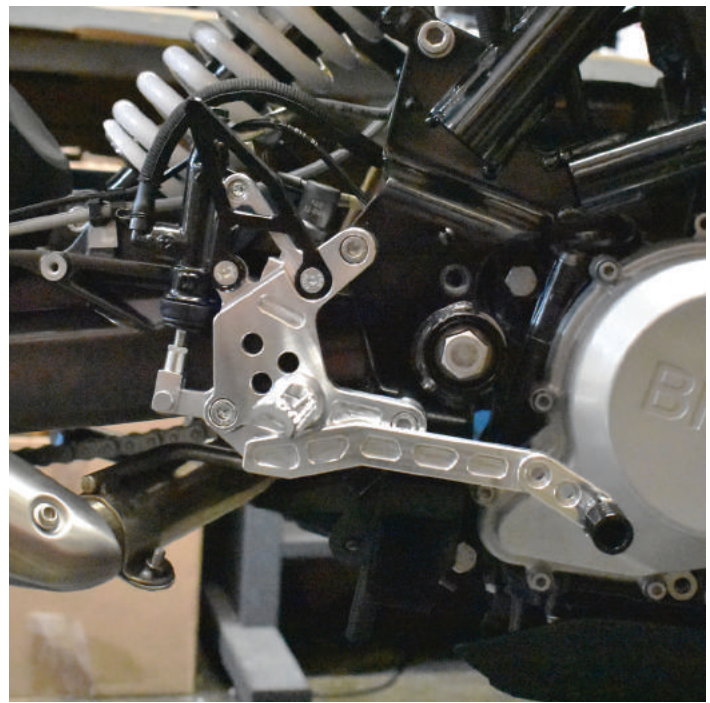

**Right Side**

\*These images are prototypes only. The actual product may look different.

**FOR OFF ROAD/RACE USE ONLY!**

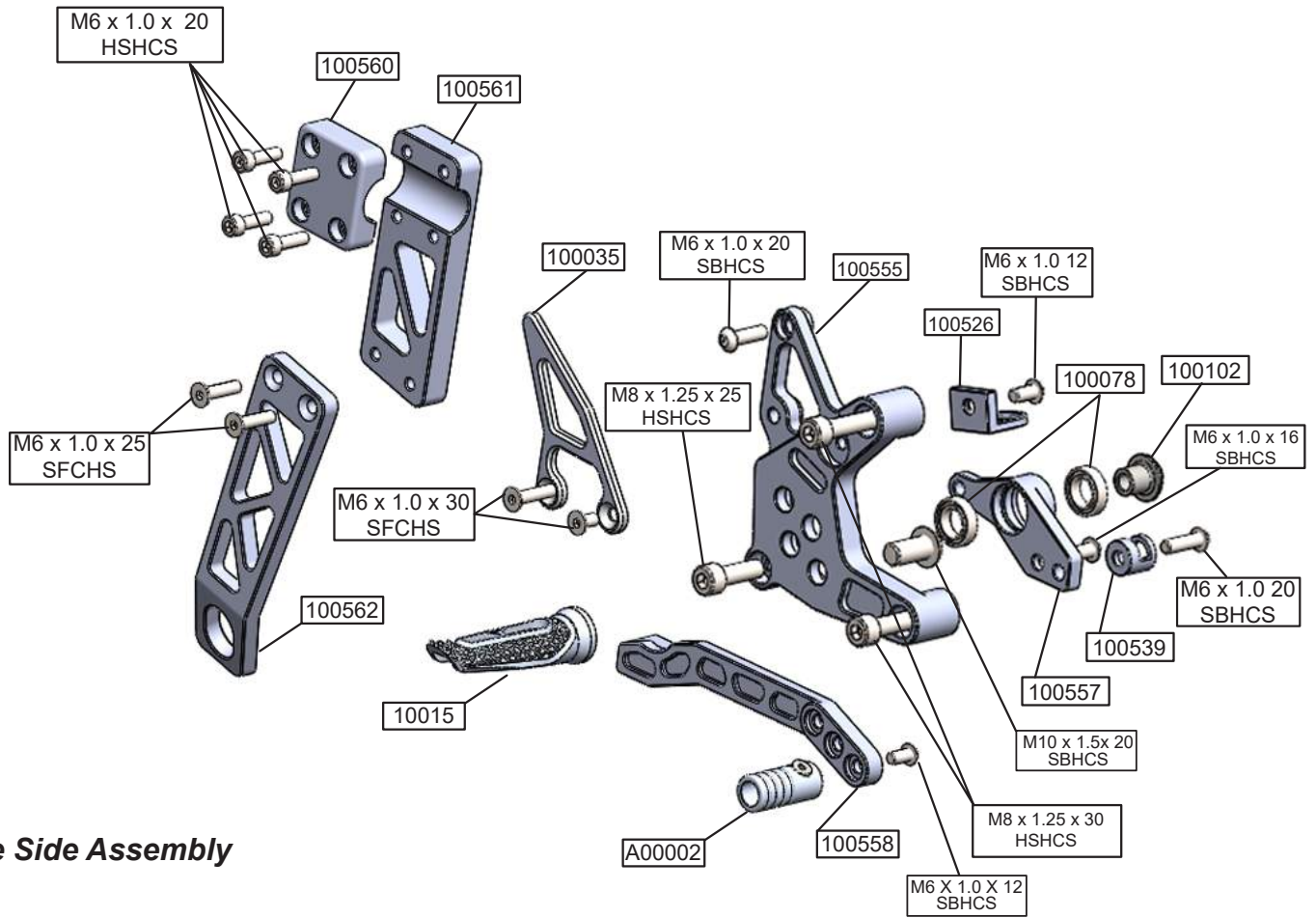

**Brake Side Assembly**

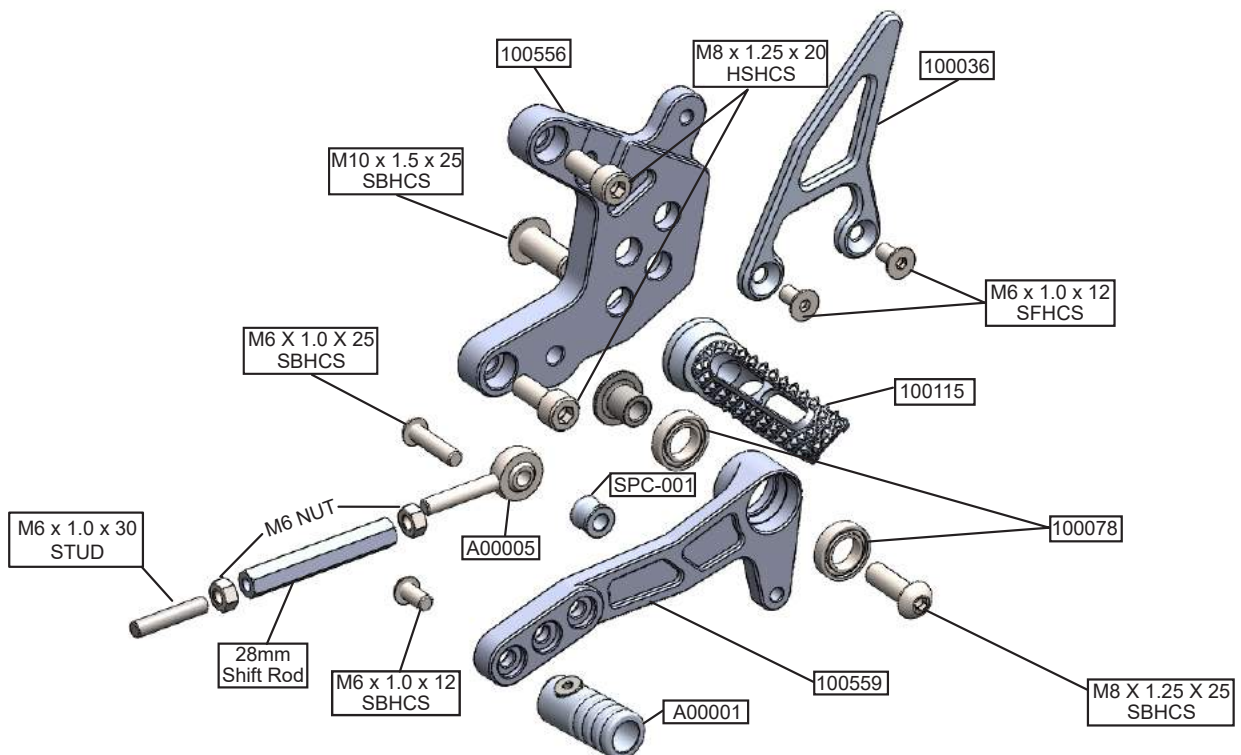

**Shift Side Assembly**