

FOR OFF ROAD/RACE USE ONLY!



Driven TT Rearsets for BMW R-9T(NOT RACER)

Part # DRP-732

Installation Instructions

Removal of Left Side

1. Remove left side (shifter side) frame bracket
2. Remove shift lever

Removal of Right Side

1. Remove right side frame bracket
2. Remove master cylinder plunger pin
3. Remove master cylinder from frame bracket
4. Remove frame bracket from bike
5. Disconnect brake switch wire from stock bracket

Tools Required

- 8mm Open End Wrench
- 5mm Hex Key
- 6mm Hex Key
- 8mm Hex Key
- Needle Nose Pliers
- Screw Driver
- Blue Loctite
- Impact Gun

THE USE OF BLUE LOCTITE IS REQUIRED ON ALL MOUNTING HARDWARE!

Installation

NOTE: ALL PIVOT POINTS MUST BE TIGHTENED USING BLUE LOCTITE AND AN IMPACT GUN.

Left Side Installation

1. Install left side foot peg into frame bracket (Stock is the bottom left hole)
2. Install frame bracket assembly onto bike
3. Install shift pedal and adjust for proper height and reach
5. Tighten all bolts and nuts (**use blue Loctite**)

TORQUE VALUES

- M5 = 6FT/LBS
- M6 = 10FT/LBS
- M8 = 25FT/LBS
- M10 = 45FT/LBS

Right Side Installation

1. Install right side foot peg into frame bracket (stock is the bottom right hole)
2. Install master cylinder into left frame bracket
3. Install master cylinder plunger pin
4. Install frame bracket to bike
5. Tighten all bolts (using blue Loctite)
6. Using supplied crimp sleeve connector with jacket connect supplied brake switch wires

Note. If "gp shift pattern" is desired rotate shift knuckle 180 degrees.

****You will have to crimp new (supplied) connectors in to OE wire harness to activate rear brake switch see fig. 1**

*****See fig. 2 for proper connection of rear brake switch (supplied)**

Make final adjustments as necessary and re-check all hardware after the first 500 miles of use.

THIS PRODUCT IS INTENDED TO BE INSTALLED BY A CERTIFIED TECHNICIAN*

FOR OFF ROAD/RACE USE ONLY!

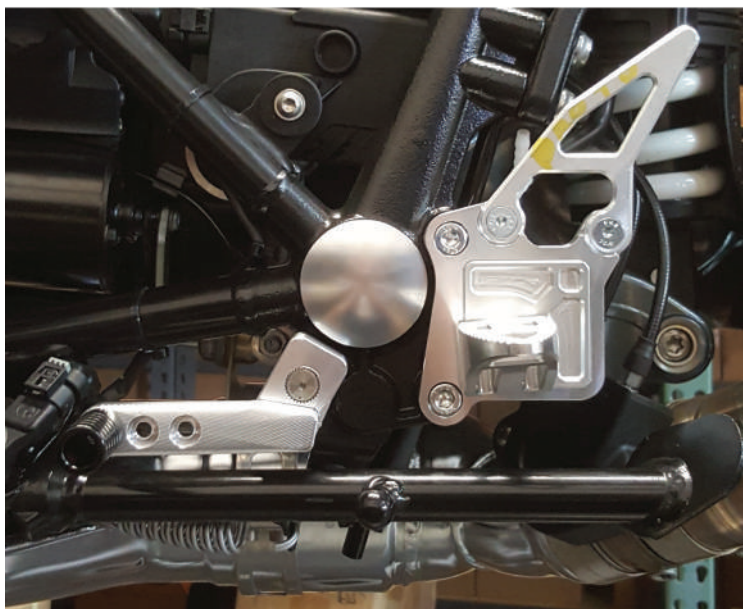

Left Side

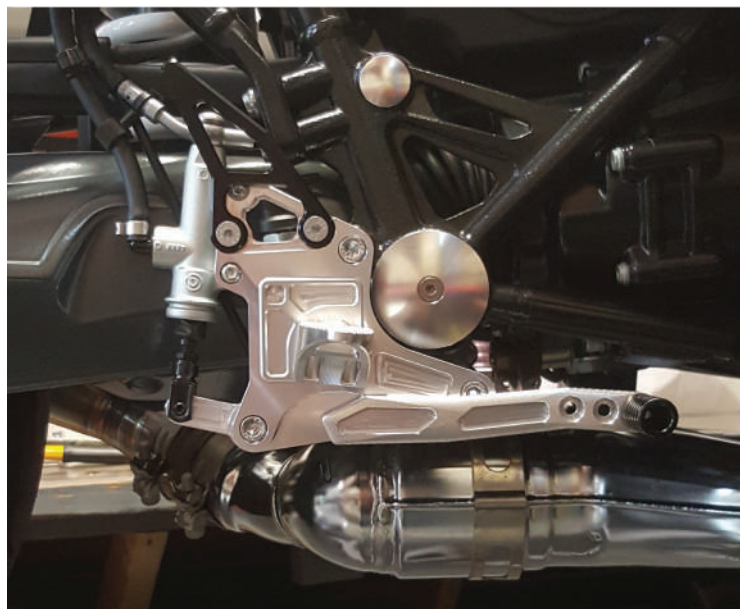

Right Side



(Fig. 1)



(Fig. 2)

THIS PRODUCT IS INTENDED TO BE INSTALLED BY A CERTIFIED TECHNICIAN*

FOR OFF ROAD/RACE USE ONLY!



DRIVEN PERFORMANCE PRODUCTS
WWW.DRIVENRACING.COM
866-5-DRIVEN

Brake Side Assembly

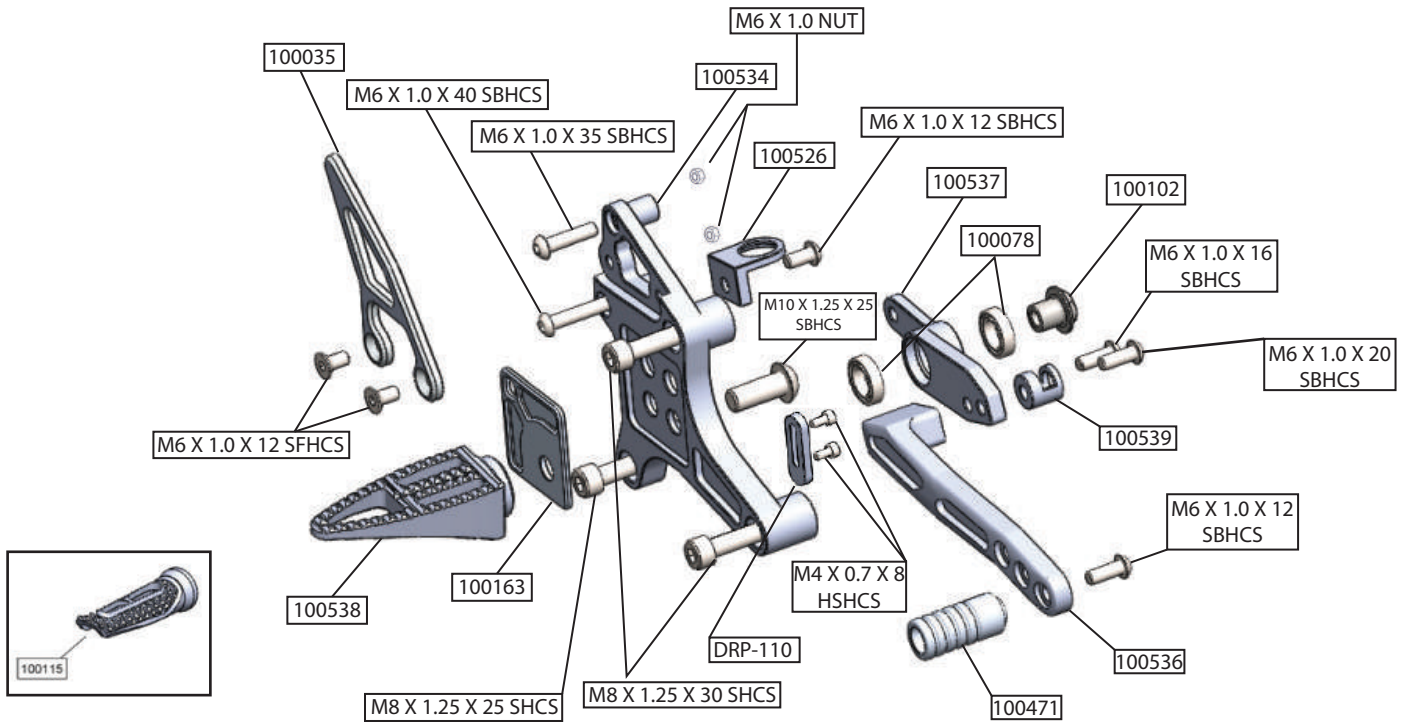

Shift Side Assembly

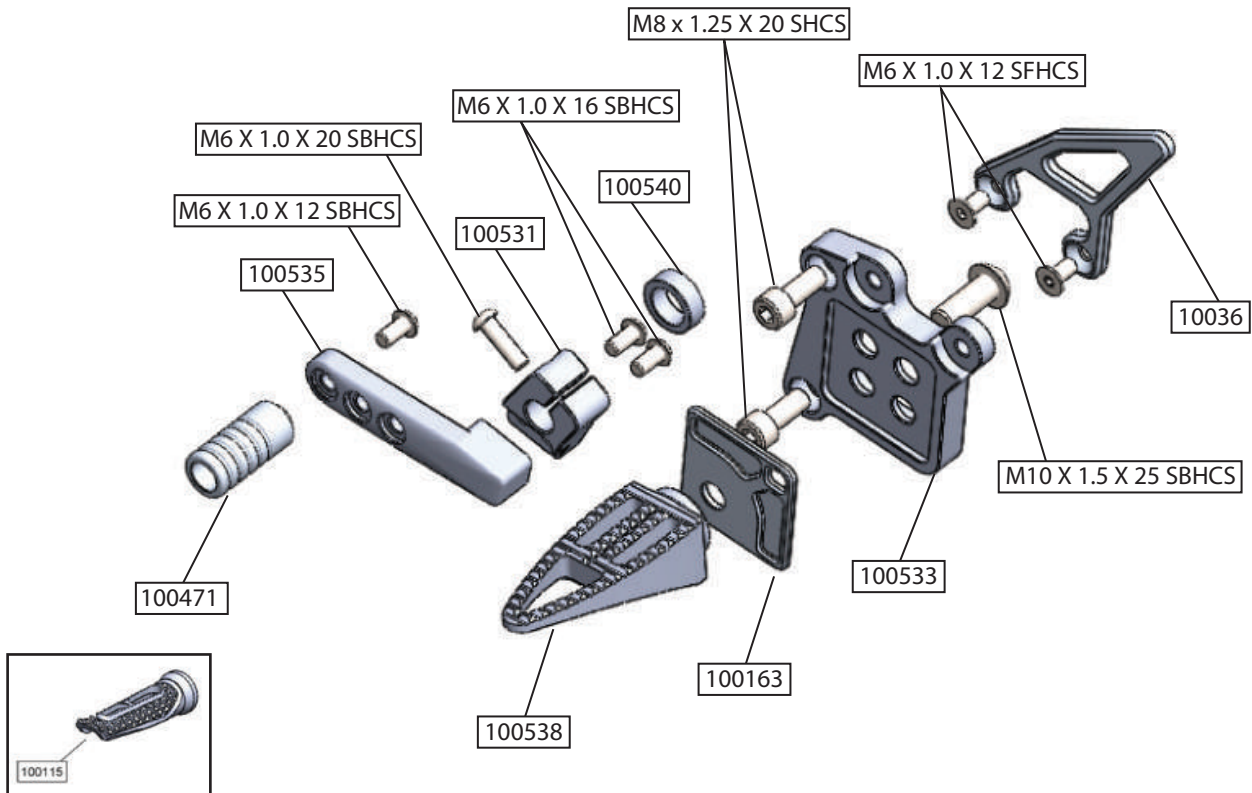

THIS PRODUCT IS INTENDED TO BE INSTALLED BY A CERTIFIED TECHNICIAN*