

**FOR OFF ROAD/RACE USE ONLY!**



**Driven TT Rearsets for 17-21 Yamaha FZ-10/MT-10**

**Part#: DRP-725**

### **INSTALLATION INSTRUCTIONS**

#### **Removal:**

##### **Shifter Side**

1. Remove OEM shift rod from bike.
2. Remove frame plate from bike.

##### **Brake Side**

1. Remove master cylinder from frame bracket.
2. Remove rear brake pedal.
3. Remove exhaust bolt.
4. Remove frame bracket.
5. Remove rear brake switch, and return spring from bracket.

#### **TOOLS REQUIRED**

- 8mm Open End Wrench
- 5mm Hex Key
- 6mm Hex Key
- 8mm Hex Key
- Needle Nose Pliers
- Screw Driver
- Blue Loctite
- Impact Gun

**THE USE OF BLUE LOCTITE IS REQUIRED ON ALL MOUNTING HARDWARE!**

#### **Installation**

NOTE: ALL PIVOT POINTS MUST BE TIGHTENED USING BLUE LOCTITE AND AN IMPACT GUN.

To retain the use of the rear brake light switch a separate M10 X 1.25 aftermarket brake light switch (not included) will need to be used.

##### **Shifter Side**

1. Install foot peg in frame bracket.
2. Install shift rod to shift arm using provided bolt and nut.
3. Connect shift arm to bike using provided spacer.
4. Install frame bracket onto bike.
5. Adjust shift lever with shift rod tighten both safety nut.
6. To set up for reverse or standard shifting see FIG. 2 or FIG. 3.

#### **TORQUE VALUES**

- M5 = 6FT/LBS
- M6 = 10FT/LBS
- M8 = 25FT/LBS
- M10 = 45FT/LBS

##### **Brake Side**

1. Install foot peg in frame bracket.
2. Connect brake switch assembly to frame bracket see FIG. 1.
3. Connect spring to brake switch(included don't use OEM spring).
4. Connect master cylinder plunger to brake lever using OEM cotter and split pin.
5. Install frame bracket to bike.
6. Connect exhaust bracket to exhaust.
7. Make sure rear brake lever has free play.
8. Make sure rear brake light switch is activating the light when you depress the rear brake pedal.
9. Use Blue Loctite on all bolts and torque all to required setting.
10. Make sure nothing interfere with proper operation of motorcycle.

***Make final adjustments as necessary and re-check all hardware after the first 500 miles of use.***

**THIS PRODUCT IS INTENDED TO BE INSTALLED BY A CERTIFIED TECHNICIAN\***

**FOR OFF ROAD/RACE USE ONLY!**

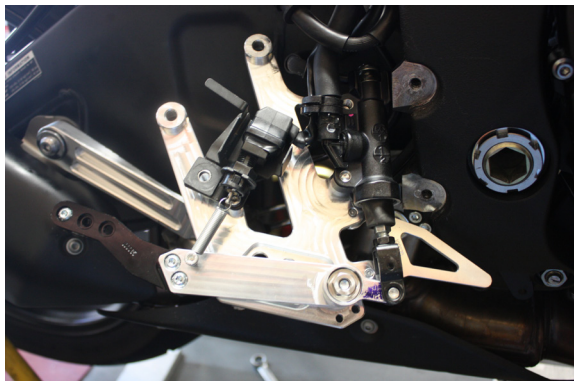

FIG 1.



FIG 2. Standard shift

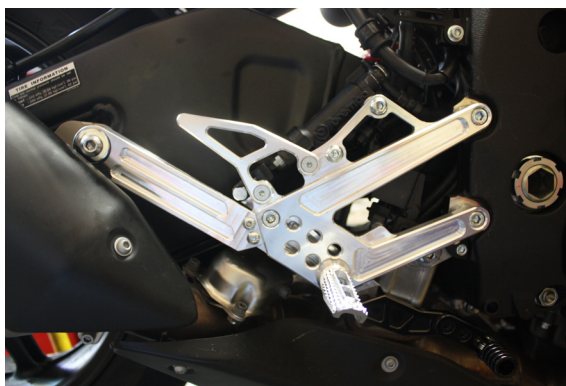
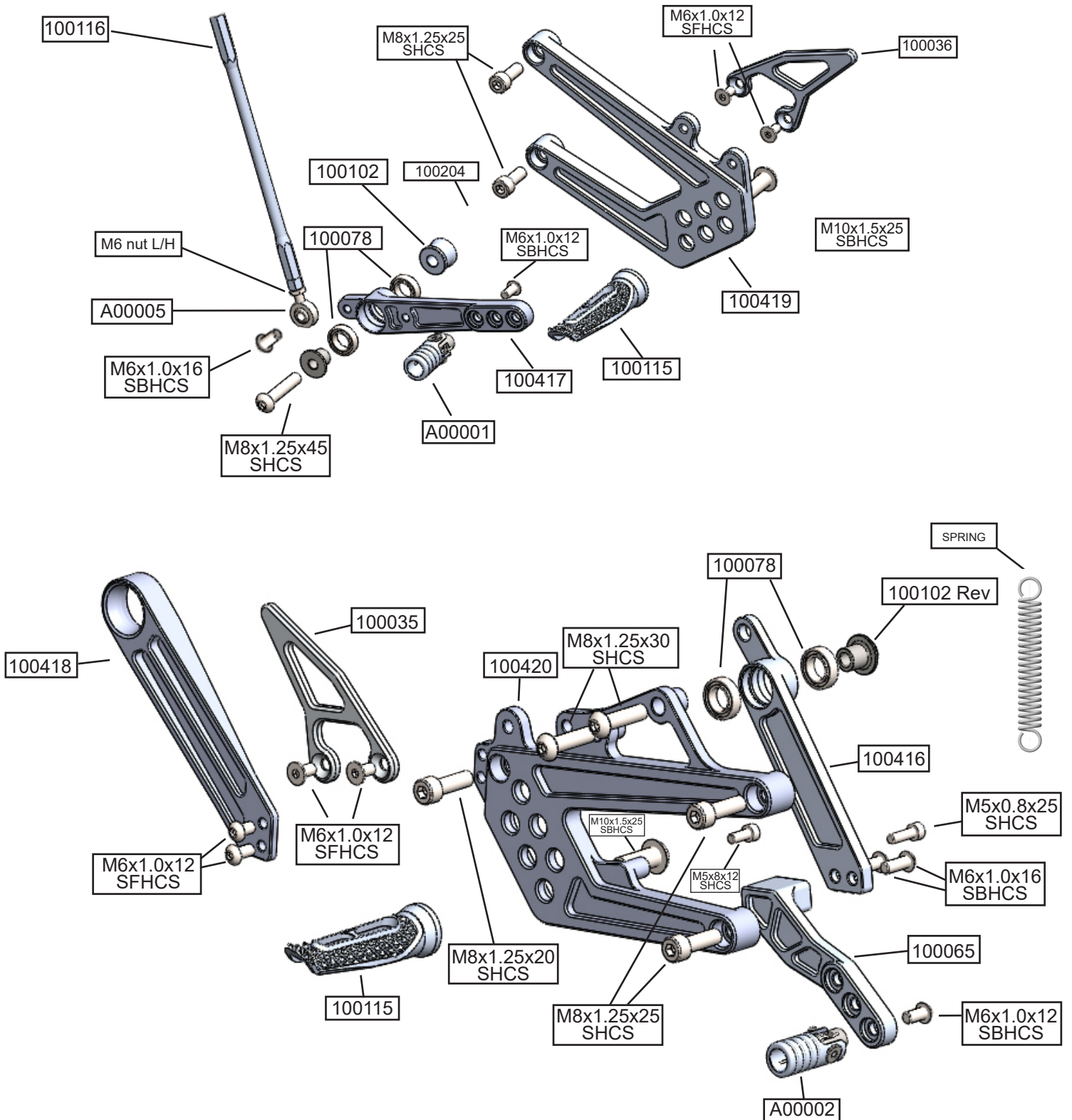

FIG 3. Reverse shift

**THIS PRODUCT IS INTENDED TO BE INSTALLED BY A CERTIFIED TECHNICIAN\***

**FOR OFF ROAD/RACE USE ONLY!**



**THIS PRODUCT IS INTENDED TO BE INSTALLED BY A CERTIFIED TECHNICIAN\***