

FOR OFF ROAD/RACE USE ONLY!



Driven TT Rearsets for BMW S1000RR 09-14

Part#: DRP-712R

INSTALLATION INSTRUCTIONS

Removal

Brake Side

1. Remove EX bracket bolt.
2. Remove 2 M6 bolts holding master cylinder.
3. Remove bracket from bike.
4. Remove plunger from brake lever.

Shifter Side

1. Remove rear set bracket from bike.
2. Remove the M6 bolt holding the quick shift assist to the shift lever.

TOOLS REQUIRED

- 8mm Open End Wrench
- 5mm Hex Key
- 6mm Hex Key
- 8mm Hex Key
- Needle Nose Pliers
- Screw Driver
- Blue Loctite
- Impact Gun

THE USE OF BLUE LOCTITE IS REQUIRED ON ALL MOUNTING HARDWARE!

Installation

NOTE: ALL PIVOT POINTS MUST BE TIGHTENED USING BLUE LOCTITE AND AN IMPACT GUN.

Brake Side

1. Install foot peg in frame bracket.
2. Connect master cylinder plunger to brake lever using OEM pin.
3. Push plunger into master cylinder and adjust free play with the slider installed.
4. Install master cylinder using 2 M6 bolts supplied.
5. Install driven rear set to bike using supplied bolts.

Shifter Side

1. Set up your shift pattern. (STD or GP see fig 1.)
2. Install foot peg in desired position.
3. Connect shift rod and shift assist to bell crank.
4. Install driven rear set on bike using supplied bolts.
5. Use blue Loctite on all bolts and torque all to required setting.
6. Make sure nothing interferes with proper operation of motorcycle.

TORQUE VALUES

- M5 = 6FT/LBS
- M6 = 10FT/LBS
- M8 = 25FT/LBS
- M10 = 45FT/LBS

Make final adjustments as necessary and re-check all hardware after the first 500 miles of use.



Brake Side (Image represents typical DRP-712 setup not the "712R")

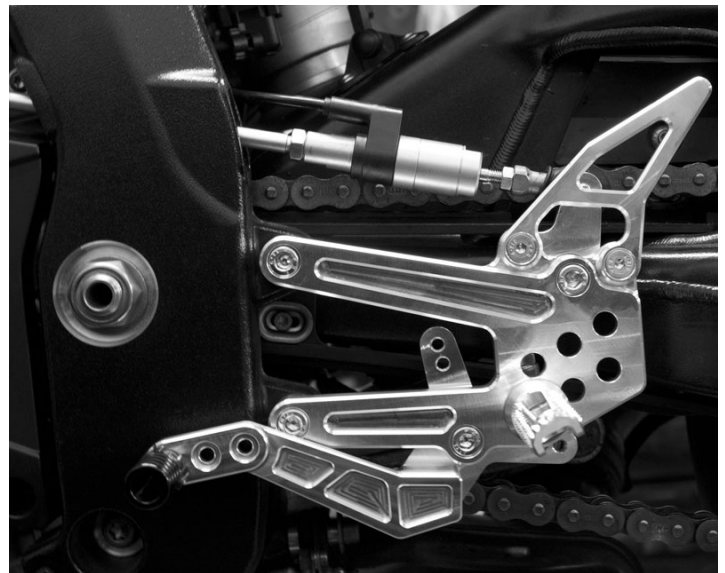

Shifter Side (Image represents typical DRP-712 setup not the "712R")

THIS PRODUCT IS INTENDED TO BE INSTALLED BY A CERTIFIED TECHNICIAN*

FOR OFF ROAD/RACE USE ONLY!

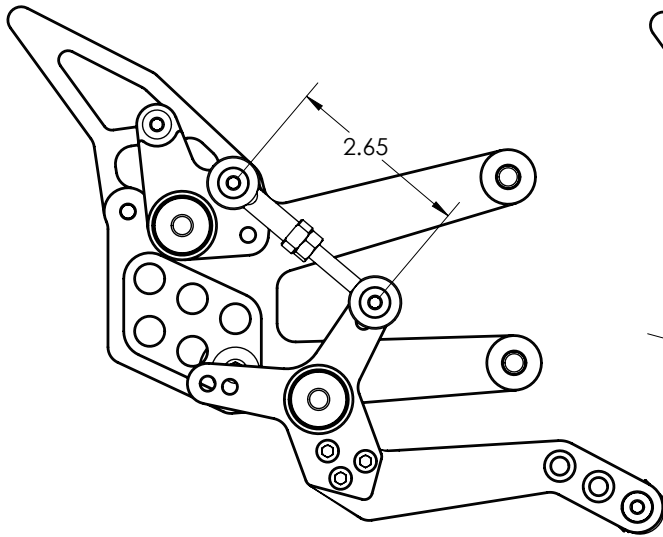

STANDARD

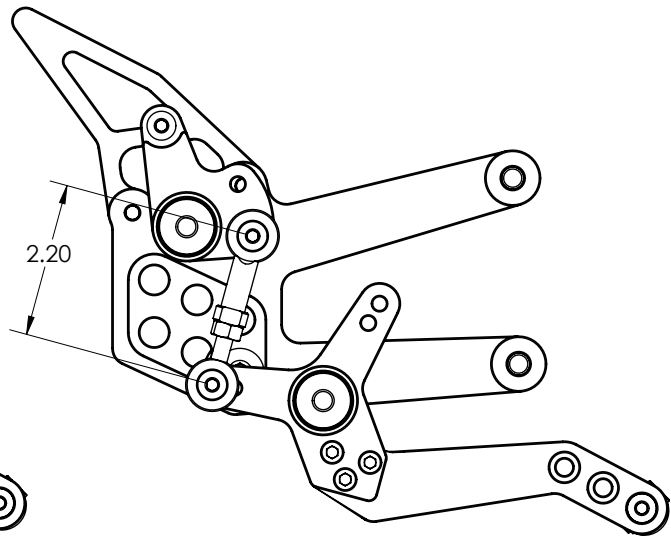

REVERSE

(FIG 1.)

THIS PRODUCT IS INTENDED TO BE INSTALLED BY A CERTIFIED TECHNICIAN*

