



DRIVEN PERFORMANCE PRODUCTS  
 9362 ETON AVE  
 UNIT B  
 CHATSWORTH, CA 91311  
 WWW.DRIVENRACING.COM 866-5-DRIVEN



09-11 YAMAHA R1 REAR SETS  
 PART#: DRP-510



INSTALLATION INSTRUCTIONS



USE BLUE LOCTITE ON ALL MOUNTING BOLTS!  
 USE LOCTITE ANTI-SEIZE ON THE HEADS OF ALL COUNTERSUNK BOLTS



1. Remove the stock footrest assemblies from both sides of the bike.
2. Loosen the jam nut on the heim joint on the gear shift arm at the shift shaft.
3. Remove the socket head shoulder bolt that retains the shifter onto the kickstand bracket.
4. Remove stock shifter and unscrew the shift rod from the upper heim joint.
5. Thread the new shift rod onto the upper heim joint (*leave jam nuts loose*)
6. Install the new shifter in the original location utilizing the included bolt and bushing.
7. Bolt the lower heim joint to the shifter.
8. Install left and right frame brackets. (*Note: install heatshield on right frame bracket with included spacer before bolting bracket to frame*)
9. Install footpeg onto footrest bracket and adjust eccentric unit to desired location, noting index marks.
10. Install left and right footrest bracket assemblies in the desired mounting hole.
11. Adjust sliding portion of the shifter unit to attain desired shifter/footpeg distance.
12. Adjust shift rod to attain desired shifter/footpeg height.
13. Tighten heim joint jam nuts to finalize shifter height.
14. Replace original master cylinder clevis with new one and mount master cylinder to master cylinder bracket.
15. Adjust clevis to attain desired brake pedal height, tighten clevis jam nut, and install clevis pin/spacer/washer/cotter pin.
16. Check torque on all mounting bolts before riding, and again after approximately 20-50 miles to verify.
17. If reverse (GP) shifting is desired, remove bolt from gear shift arm and rotate the arm 180°, then reinstall arm and bolt.

DRIVEN REQUIRES THIS PRODUCT TO BE INSTALLED BY A CERTIFIED TECHNICIAN

TOOLS REQUIRED



- 6mm hex key
- 5mm hex key
- 4mm hex key
- 8mm end wrench (*optional – to remove gear shift arm for reverse shifting*)
- 10mm end wrench (*for jam nuts*)
- 12mm end wrench (*for clevis jam nut*)
- 3/8" end wrench (*for new shift rod*)
- Needle-nose pliers (*for cotter pin*)
- Blue Loctite (#242)
- Loctite Anti-Seize Lubricant

TORQUE SPECS AND INFO



- M10x1.5 – 55ft-lb (660in-lb)
- M8x1.25 – 20ft-lb (240in-lb)
- M6x1.0 – 13ft-lb (156in-lb)
- M5x0.8 – 5ft-lb (60in-lb)

\*OEM height set at the lowest forward mounting hole with the foot peg set at the zero position.

**\*FOR OFF ROAD / CLOSED COURSE USE ONLY**

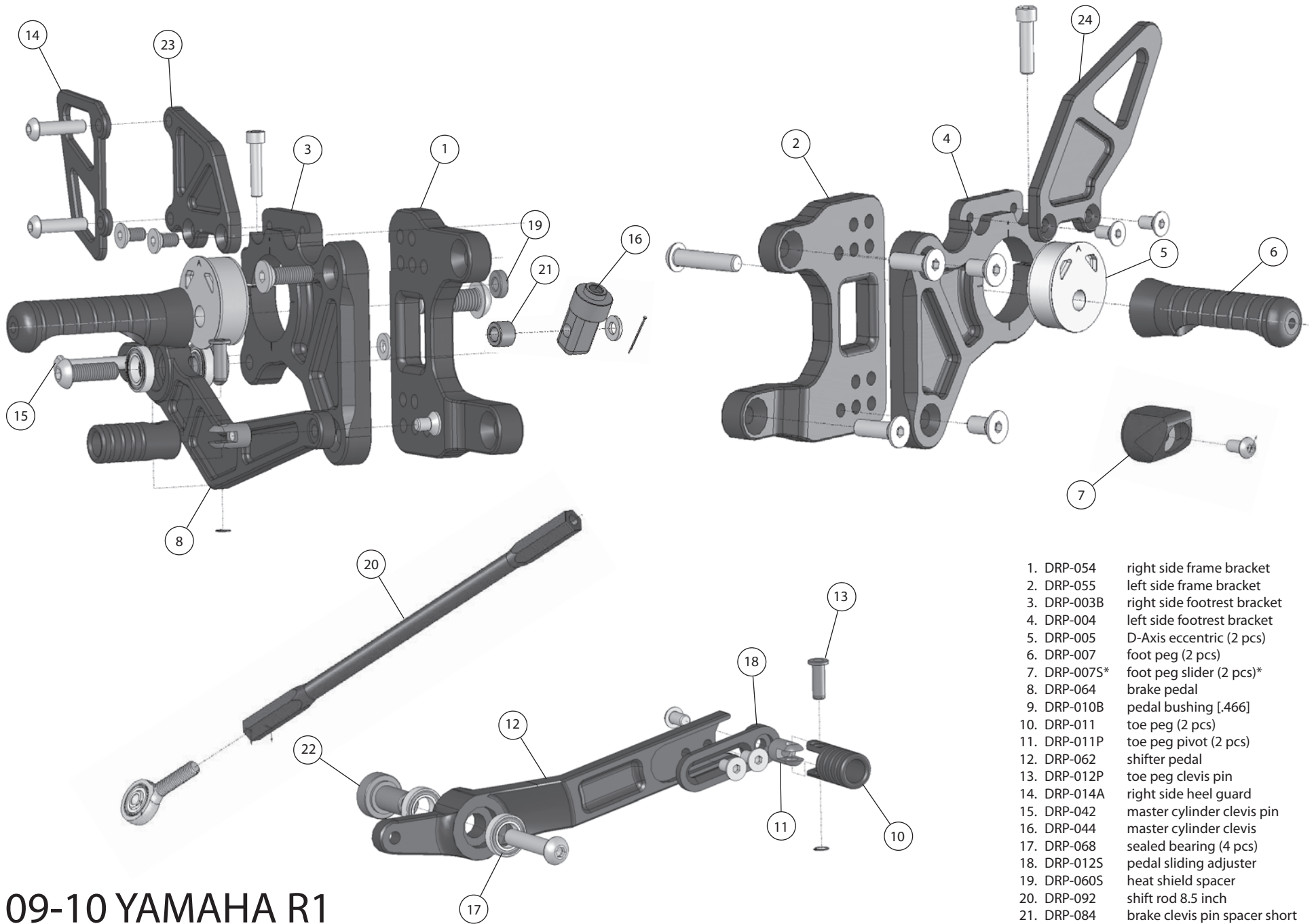

- |              |                               |
|--------------|-------------------------------|
| 1. DRP-054   | right side frame bracket      |
| 2. DRP-055   | left side frame bracket       |
| 3. DRP-003B  | right side footrest bracket   |
| 4. DRP-004   | left side footrest bracket    |
| 5. DRP-005   | D-Axis eccentric (2 pcs)      |
| 6. DRP-007   | foot peg (2 pcs)              |
| 7. DRP-007S* | foot peg slider (2 pcs)*      |
| 8. DRP-064   | brake pedal                   |
| 9. DRP-010B  | pedal bushing [.466]          |
| 10. DRP-011  | toe peg (2 pcs)               |
| 11. DRP-011P | toe peg pivot (2 pcs)         |
| 12. DRP-062  | shifter pedal                 |
| 13. DRP-012P | toe peg clevis pin            |
| 14. DRP-014A | right side heel guard         |
| 15. DRP-042  | master cylinder clevis pin    |
| 16. DRP-044  | master cylinder clevis        |
| 17. DRP-068  | sealed bearing (4 pcs)        |
| 18. DRP-012S | pedal sliding adjuster        |
| 19. DRP-060S | heat shield spacer            |
| 20. DRP-092  | shift rod 8.5 inch            |
| 21. DRP-084  | brake clevis pin spacer short |
| 22. DRP-062B | shifter pedal bushing         |
| 23. DRP-053  | master cylinder bracket       |
| 24. DRP-030  | left side heel guard          |

09-10 YAMAHA R1  
PART#: DRP-510