



DRIVEN PERFORMANCE PRODUCTS
 9362 ETON AVE
 UNIT B
 CHATSWORTH, CA 91311
 WWW.DRIVENRACING.COM 866-5-DRIVEN



06-10 KAWASAKI ZX-10R REAR SETS
 PART#: DRP-506



INSTALLATION INSTRUCTIONS



USE BLUE LOCTITE ON ALL MOUNTING BOLTS!
 USE LOCTITE ANTI-SEIZE ON THE HEADS OF ALL COUNTERSUNK BOLTS



1. Remove the stock footrest assemblies from both sides of the bike.
2. Loosen the jam nut on the heim joint on the gear shift arm at the shift shaft.
3. Unscrew the shift rod from the gear shift arm's heim joint.
4. Install left and right frame brackets.
5. Install footpeg onto footrest bracket and adjust eccentric unit to desired location, noting index marks.
6. Thread the new shift rod onto the gear shift arm's heim joint (*leave jam nuts loose*)
7. Bolt the other heim joint to the inside of the shifter, installing the supplied washer between the two.
8. Install left and right footrest bracket assemblies in the desired mounting hole.
9. Adjust shift rod to attain desired shifter/footpeg height. (*use the 6.5" shift rod for the forward positions, I.E. – stock location/12mm up/12mm back...8" for all other positions*)
10. Tighten heim joint jam nuts to finalize shifter height.
11. Replace original master cylinder clevis with new one and mount master cylinder to master cylinder bracket.
12. Adjust clevis to attain desired brake pedal height, tighten clevis jam nut, and install clevis pin/spacer/washer/cotter pin.
13. Check torque on all mounting bolts before riding, and again after approximately 20-50 miles to verify.
14. If reverse (GP) shifting is desired, remove bolt from gear shift arm and rotate the arm 180°, then reinstall arm and bolt. (*'06-'07 bikes will need to have the lower fairing trimmed as marked in the accompanying photo if used in the reverse position, in order to have sufficient clearance*)



Fig. 2

DRIVEN REQUIRES THIS PRODUCT TO BE INSTALLED BY A CERTIFIED TECHNICIAN

TOOLS REQUIRED



- 6mm hex key
- 5mm hex key
- 4mm hex key
- 8mm end wrench (*optional – to remove gear shift arm for reverse shifting*)
- 10mm end wrench (*for jam nuts*)
- 12mm end wrench (*for clevis jam nut*)
- 3/8" end wrench (*for new shift rod*)
- Needle-nose pliers
- Blue Loctite (#242)
- Loctite Anti-Seize Lubricant

TORQUE SPECS AND INFO



- M10x1.5 – 55ft-lb (660in-lb)
- M8x1.25 – 20ft-lb (240in-lb)
- M6x1.0 – 13ft-lb (156in-lb)
- M5x0.8 – 5ft-lb (60in-lb)

*OEM height set at the lowest forward mounting hole with the foot peg set at the zero position.

***FOR OFF ROAD / CLOSED COURSE USE ONLY**

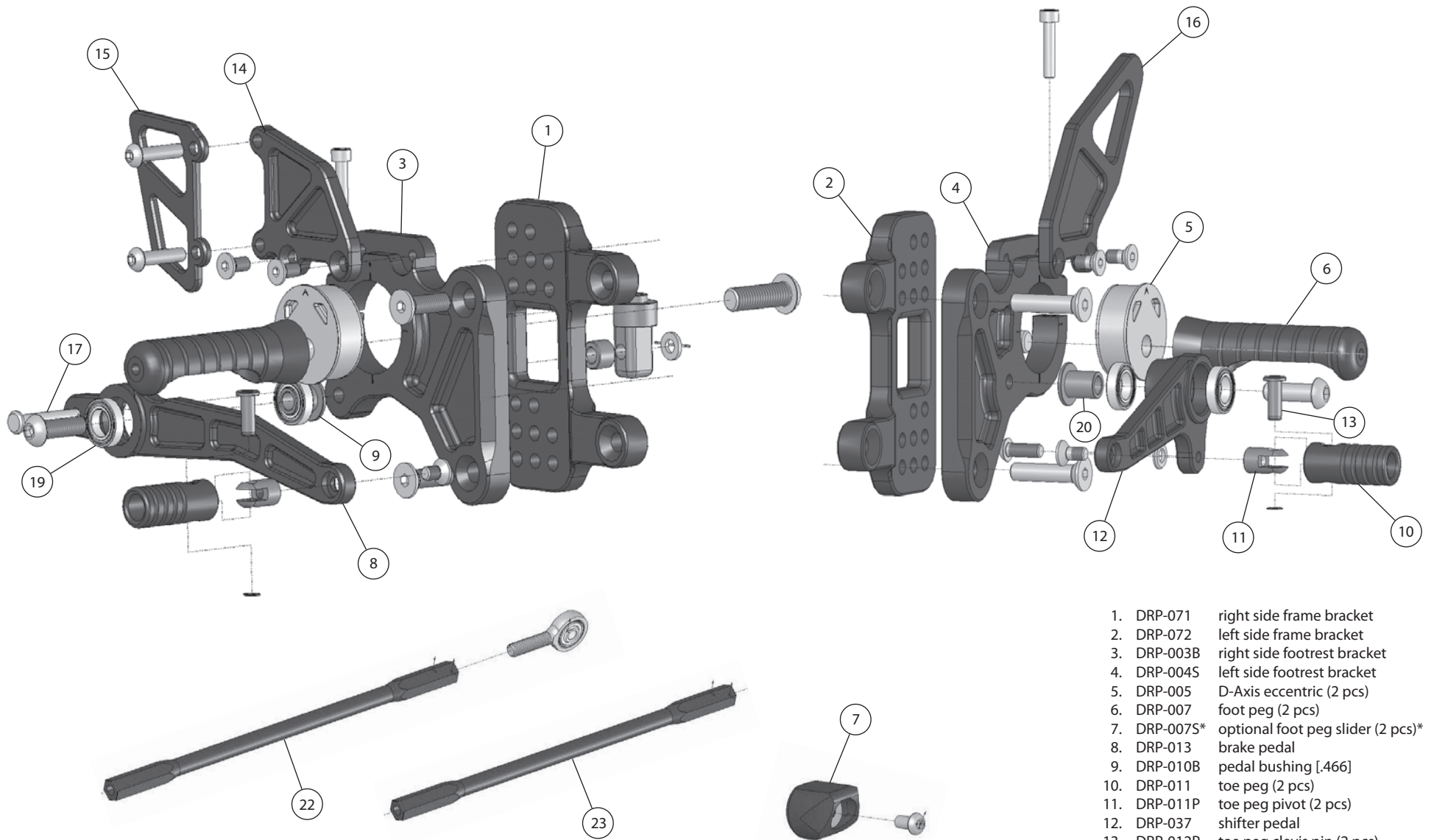

1. DRP-071 right side frame bracket
2. DRP-072 left side frame bracket
3. DRP-003B right side footrest bracket
4. DRP-004S left side footrest bracket
5. DRP-005 D-Axis eccentric (2 pcs)
6. DRP-007 foot peg (2 pcs)
7. DRP-007S* optional foot peg slider (2 pcs)*
8. DRP-013 brake pedal
9. DRP-010B pedal bushing [.466]
10. DRP-011 toe peg (2 pcs)
11. DRP-011P toe peg pivot (2 pcs)
12. DRP-037 shifter pedal
13. DRP-012P toe peg clevis pin (2 pcs)
14. DRP-068 master cylinder bracket
15. DRP-070 right side heel guard
16. DRP-030 left side heel guard
17. DRP-042 master cylinder clevis pin
18. DRP-044 master cylinder clevis
19. DRP-068 sealed bearing (4 pcs)
20. DRP-037B shifter pedal bushing
21. DRP-084 brake clevis pin spacer
22. DRP-090 shift rod 6.5 inch
23. DRP-092 shift rod 8.5 inch

06-10 KAWASAKI ZX-10R
PART#: DRP506